



用心智造·让产品更贴近生活  
MAKE PRODUCTS CLOSER TO LIFE WITH MIND

WE SUPPORT CUSTOMIZING VARIOUS TYPES OF  
ALUMINUM MATERIALS BASED ON SAMPLES!

支持来样定制各种型号铝材!



WHATSAAPP 商业客户



扫一扫，加好友

温馨提示:

- 1、图片尺寸与实物尺寸有差异，本公司有权修改取用上述产品。
- 2、有关工程项目的具体尺寸、数据请与本公司联系确认。
- 3、由于印刷关系，证实产品颜色与所示的图片如有部分差异，一切以实物颜色为准，敬请谅解!

# 中国铝材行业品牌先锋

CHINA'S ALUMINUM INDUSTRY BRAND PIONEER

我们的理想，是成为具有强大国际竞争力的品牌企业。这意味着在规模上、质量上、效益上做到行业领先水平。

超越自我，不断追求，是建设世界品牌企业必备的思维模式。

我们必须时刻关注市场和客户的需求，成为行业的挖掘者、引导者和创造者；高度重视研发和创新，打造先进的科技创新和产品开发能力；牢固树立资源危机感，立足全球系统谋划，培育科技技术的资源保障能力；不断完善标准化管理模式，锻造流畅的企业运营能力；面向市场，造就先进的国际化人才队伍；以人为本，塑造负责任、讲诚信、善协作、求卓越的企业文化。

OUR IDEAL IS TO BECOME A BRAND ENTERPRISE WITH STRONG INTERNATIONAL COMPETITIVENESS. THIS MEANS ACHIEVING INDUSTRY-LEADING LEVELS IN TERMS OF SCALE, QUALITY AND EFFICIENCY.

SURPASSING ONESELF AND CONSTANTLY PURSUING ARE THE ESSENTIAL THINKING PATTERNS FOR BUILDING A WORLD-CLASS BRAND ENTERPRISE.

WE MUST ALWAYS KEEP AN EYE ON THE DEMANDS OF THE MARKET AND CUSTOMERS, AND BECOME THE EXPLORERS, LEADERS AND CREATORS OF THE INDUSTRY. ATTACH GREAT IMPORTANCE TO RESEARCH AND DEVELOPMENT AND INNOVATION, AND BUILD ADVANCED CAPABILITIES IN SCIENTIFIC AND TECHNOLOGICAL INNOVATION AND PRODUCT DEVELOPMENT; FIRMLY ESTABLISH A SENSE OF RESOURCE CRISIS, PLAN SYSTEMATICALLY FROM A GLOBAL PERSPECTIVE, AND CULTIVATE THE RESOURCE GUARANTEE CAPACITY OF SCIENCE AND TECHNOLOGY. CONSTANTLY IMPROVE THE STANDARD QUANTITATIVE MANAGEMENT MODEL AND FORGE SMOOTH ENTERPRISE OPERATION CAPABILITIES; FACING THE MARKET, CULTIVATE AN ADVANCED INTERNATIONAL TALENT TEAM; PEOPLE-ORIENTED, WE SHAPE A CORPORATE CULTURE THAT IS RESPONSIBLE, HONEST, COLLABORATIVE AND STRIVING FOR EXCELLENCE.





用心智造·让产品更贴近生活  
MAKE PRODUCTS CLOSER TO LIFE WITH MIND

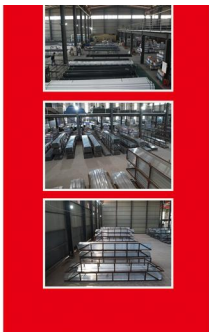
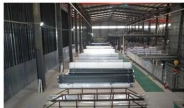
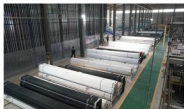

## 先进的生产车间

### ADVANCED PRODUCTION WORKSHOP

公司具备科学完善的管理模式，先进的生产设备，雄厚的研发实力，领先的技术优势，强大的年生产能力，遍布全国的销售网络和形式多样的混合型营销服务平台，让公司实现了几何级数快速增长……

The COMPANY has scientific and perfect management model, advanced production equipment, strong R&D strength, leading technology advantage, strong annual production capacity, sales network all over the country and various forms of hybrid marketing service platform, the COMPANY has achieved geometric rapid growth……





GS73断桥隔热内开窗系列  
GS73 SERIES OF THERMAL BREAK INSULATED INWARD-OPENING WINDOWS

科技改变未来  
Technology changes the future



## GS73系列内开窗

THE GS73 SERIES HAS INWARD-OPENING WINDOWS

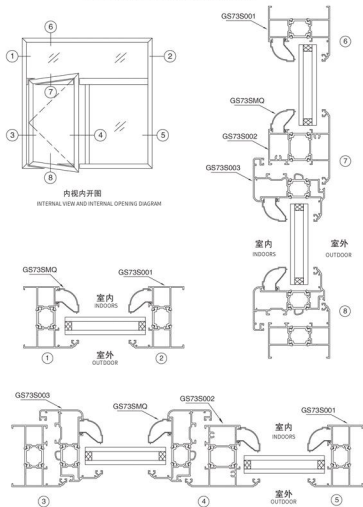

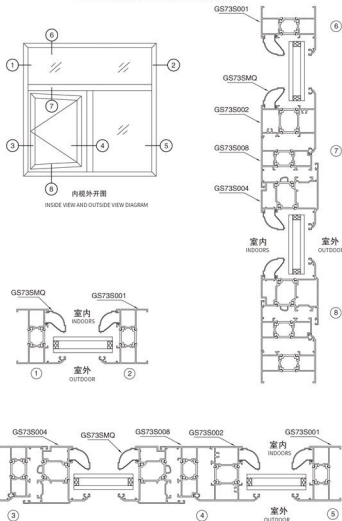

**GS73系列外开窗**

THE GS73 SERIES HAS INWARD-OPENING WINDOWS

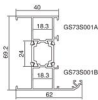
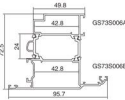
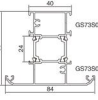
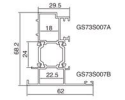
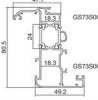
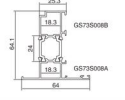
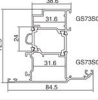
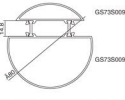

图中所示为理论重量, 客户可根据需要的厚度订购, 实际重量以过磅时重量为准。

The theoretical weight is shown in the picture. Customers can order according to the thickness they need. The actual weight is subject to the weight at the time of weighing.

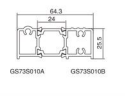
<table border="1"> <tr><td>编号 Number</td><td>GS73S001</td></tr> <tr><td>名称 Name</td><td>框扇</td></tr> <tr><td>壁厚 Wall thickness</td><td>1.3mm</td></tr> <tr><td>米重 M.Zhong</td><td>1.236kg/m</td></tr> </table>	编号 Number	GS73S001	名称 Name	框扇	壁厚 Wall thickness	1.3mm	米重 M.Zhong	1.236kg/m		<table border="1"> <tr><td>编号 Number</td><td>GS73S006</td></tr> <tr><td>名称 Name</td><td>外开门扇 External door panel</td></tr> <tr><td>壁厚 Wall thickness</td><td>1.3mm</td></tr> <tr><td>米重 M.Zhong</td><td>1.668kg/m</td></tr> </table>	编号 Number	GS73S006	名称 Name	外开门扇 External door panel	壁厚 Wall thickness	1.3mm	米重 M.Zhong	1.668kg/m	
编号 Number	GS73S001																		
名称 Name	框扇																		
壁厚 Wall thickness	1.3mm																		
米重 M.Zhong	1.236kg/m																		
编号 Number	GS73S006																		
名称 Name	外开门扇 External door panel																		
壁厚 Wall thickness	1.3mm																		
米重 M.Zhong	1.668kg/m																		
<table border="1"> <tr><td>编号 Number</td><td>GS73S002</td></tr> <tr><td>名称 Name</td><td>框扇</td></tr> <tr><td>壁厚 Wall thickness</td><td>1.3mm</td></tr> <tr><td>米重 M.Zhong</td><td>1.521kg/m</td></tr> </table>	编号 Number	GS73S002	名称 Name	框扇	壁厚 Wall thickness	1.3mm	米重 M.Zhong	1.521kg/m		<table border="1"> <tr><td>编号 Number</td><td>GS73S007</td></tr> <tr><td>名称 Name</td><td>框中框 Fixing-in-to-frame</td></tr> <tr><td>壁厚 Wall thickness</td><td>1.3mm</td></tr> <tr><td>米重 M.Zhong</td><td>1.243kg/m</td></tr> </table>	编号 Number	GS73S007	名称 Name	框中框 Fixing-in-to-frame	壁厚 Wall thickness	1.3mm	米重 M.Zhong	1.243kg/m	
编号 Number	GS73S002																		
名称 Name	框扇																		
壁厚 Wall thickness	1.3mm																		
米重 M.Zhong	1.521kg/m																		
编号 Number	GS73S007																		
名称 Name	框中框 Fixing-in-to-frame																		
壁厚 Wall thickness	1.3mm																		
米重 M.Zhong	1.243kg/m																		
<table border="1"> <tr><td>编号 Number</td><td>GS73S003</td></tr> <tr><td>名称 Name</td><td>内开扇 Inner opening fan</td></tr> <tr><td>壁厚 Wall thickness</td><td>1.3mm</td></tr> <tr><td>米重 M.Zhong</td><td>1.434kg/m</td></tr> </table>	编号 Number	GS73S003	名称 Name	内开扇 Inner opening fan	壁厚 Wall thickness	1.3mm	米重 M.Zhong	1.434kg/m		<table border="1"> <tr><td>编号 Number</td><td>GS73S008</td></tr> <tr><td>名称 Name</td><td>轉換框 Conversion box</td></tr> <tr><td>壁厚 Wall thickness</td><td>1.3mm</td></tr> <tr><td>米重 M.Zhong</td><td>1.12kg/m</td></tr> </table>	编号 Number	GS73S008	名称 Name	轉換框 Conversion box	壁厚 Wall thickness	1.3mm	米重 M.Zhong	1.12kg/m	
编号 Number	GS73S003																		
名称 Name	内开扇 Inner opening fan																		
壁厚 Wall thickness	1.3mm																		
米重 M.Zhong	1.434kg/m																		
编号 Number	GS73S008																		
名称 Name	轉換框 Conversion box																		
壁厚 Wall thickness	1.3mm																		
米重 M.Zhong	1.12kg/m																		
<table border="1"> <tr><td>编号 Number</td><td>GS73S004</td></tr> <tr><td>名称 Name</td><td>外开扇 Outer-opening fan</td></tr> <tr><td>壁厚 Wall thickness</td><td>1.3mm</td></tr> <tr><td>米重 M.Zhong</td><td>1.514kg/m</td></tr> </table>	编号 Number	GS73S004	名称 Name	外开扇 Outer-opening fan	壁厚 Wall thickness	1.3mm	米重 M.Zhong	1.514kg/m		<table border="1"> <tr><td>编号 Number</td><td>GS73S009</td></tr> <tr><td>名称 Name</td><td>万向转角 Universal corner</td></tr> <tr><td>壁厚 Wall thickness</td><td>1.3mm</td></tr> <tr><td>米重 M.Zhong</td><td>1.608kg/m</td></tr> </table>	编号 Number	GS73S009	名称 Name	万向转角 Universal corner	壁厚 Wall thickness	1.3mm	米重 M.Zhong	1.608kg/m	
编号 Number	GS73S004																		
名称 Name	外开扇 Outer-opening fan																		
壁厚 Wall thickness	1.3mm																		
米重 M.Zhong	1.514kg/m																		
编号 Number	GS73S009																		
名称 Name	万向转角 Universal corner																		
壁厚 Wall thickness	1.3mm																		
米重 M.Zhong	1.608kg/m																		
<table border="1"> <tr><td>编号 Number</td><td>GS73S005</td></tr> <tr><td>名称 Name</td><td>内开扇 Inner opening fan</td></tr> <tr><td>壁厚 Wall thickness</td><td>1.3mm</td></tr> <tr><td>米重 M.Zhong</td><td>1.653kg/m</td></tr> </table>	编号 Number	GS73S005	名称 Name	内开扇 Inner opening fan	壁厚 Wall thickness	1.3mm	米重 M.Zhong	1.653kg/m		<table border="1"> <tr><td>编号 Number</td><td>GS73S010</td></tr> <tr><td>名称 Name</td><td>门框 Threshold</td></tr> <tr><td>壁厚 Wall thickness</td><td>1.9mm</td></tr> <tr><td>米重 M.Zhong</td><td>1.304kg/m</td></tr> </table>	编号 Number	GS73S010	名称 Name	门框 Threshold	壁厚 Wall thickness	1.9mm	米重 M.Zhong	1.304kg/m	
编号 Number	GS73S005																		
名称 Name	内开扇 Inner opening fan																		
壁厚 Wall thickness	1.3mm																		
米重 M.Zhong	1.653kg/m																		
编号 Number	GS73S010																		
名称 Name	门框 Threshold																		
壁厚 Wall thickness	1.9mm																		
米重 M.Zhong	1.304kg/m																		

图中所示为理论重量, 客户可根据需要的厚度订购, 实际重量以过磅时重量为准。

The theoretical weight is shown in the picture. Customers can order according to the thickness they need. The actual weight is subject to the weight at the time of weighing.







编号 Number	GS5502
名称 Name	GS5502A
框 box	GS5502B
壁厚 Wall thickness	1.1/1.3mm
重量 M.Zhong	0.913/1.007kg/m



编号 Number	GS5507
名称 Name	GS5507A
外开窗 Casement-opening for	GS5507B
壁厚 Wall thickness	1.1/1.3mm
重量 M.Zhong	1.153/1.272kg/m



编号 Number	GS5503
名称 Name	GS5503A
框 box	GS5503B
壁厚 Wall thickness	1.1/1.3mm
重量 M.Zhong	0.938/1.037kg/m



编号 Number	GS5508
名称 Name	GS5508B
替换料 Conversion material	GS5508A
壁厚 Wall thickness	1.15mm
重量 M.Zhong	0.874kg/m



编号 Number	GS5504
名称 Name	GS5504A
框 box	GS5504B
壁厚 Wall thickness	1.1/1.3mm
重量 M.Zhong	0.975/1.081kg/m



编号 Number	GS5509
名称 Name	GS5509A
门框 Door frame	GS5509B
壁厚 Wall thickness	1.35mm
重量 M.Zhong	1.148kg/m



编号 Number	GS5505
名称 Name	GS5505A
框 pretty	GS5505B
壁厚 Wall thickness	1.1/1.3mm
重量 M.Zhong	1.082/1.183kg/m



编号 Number	GS5510
名称 Name	GS5510B
门框 The door is upright	GS5510A
壁厚 Wall thickness	1.3mm
重量 M.Zhong	1.38kg/m



编号 Number	GS5506
名称 Name	GS5506A
内开窗 Inner opening for	GS5506B
壁厚 Wall thickness	1.1/1.3mm
重量 M.Zhong	1.061/1.205kg/m



编号 Number	GS5511
名称 Name	GS5511B
门框 Inner opening for	GS5511A
壁厚 Wall thickness	1.35mm
重量 M.Zhong	1.504kg/m



编号 Number	GS5507
名称 Name	GS5507A
框 box	GS5507B
壁厚 Wall thickness	1.1/1.3mm
重量 M.Zhong	0.913/1.007kg/m



编号 Number	GS5507
名称 Name	GS5507A
外开窗 Casement-opening for	GS5507B
壁厚 Wall thickness	1.1/1.3mm
重量 M.Zhong	1.153/1.272kg/m



编号 Number	GS5503
名称 Name	GS5503A
框 box	GS5503B
壁厚 Wall thickness	1.1/1.3mm
重量 M.Zhong	0.938/1.037kg/m



编号 Number	GS5508
名称 Name	GS5508B
替换料 Conversion material	GS5508A
壁厚 Wall thickness	1.15mm
重量 M.Zhong	0.874kg/m



编号 Number	GS5504
名称 Name	GS5504A
框 box	GS5504B
壁厚 Wall thickness	1.1/1.3mm
重量 M.Zhong	0.975/1.081kg/m



编号 Number	GS5509
名称 Name	GS5509A
门框 Door frame	GS5509B
壁厚 Wall thickness	1.35mm
重量 M.Zhong	1.148kg/m



编号 Number	GS5505
名称 Name	GS5505A
框 pretty	GS5505B
壁厚 Wall thickness	1.1/1.3mm
重量 M.Zhong	1.082/1.183kg/m



编号 Number	GS5510
名称 Name	GS5510B
门框 The door is upright	GS5510A
壁厚 Wall thickness	1.3mm
重量 M.Zhong	1.38kg/m



编号 Number	GS5506
名称 Name	GS5506A
内开窗 Inner opening for	GS5506B
壁厚 Wall thickness	1.1/1.3mm
重量 M.Zhong	1.061/1.205kg/m



编号 Number	GS5511
名称 Name	GS5511B
门框 Inner opening for	GS5511A
壁厚 Wall thickness	1.35mm
重量 M.Zhong	1.504kg/m



图中所示为理论重量, 客户可根据需要的厚度订购, 实际重量以过磅时重量为准。

图中所示为理论重量, 客户可根据需要的厚度订购, 实际重量以过磅时重量为准。

**LM70系列隔热内开窗**  
 LM70 SERIES INSULATED INWARD-OPENING WINDOWS

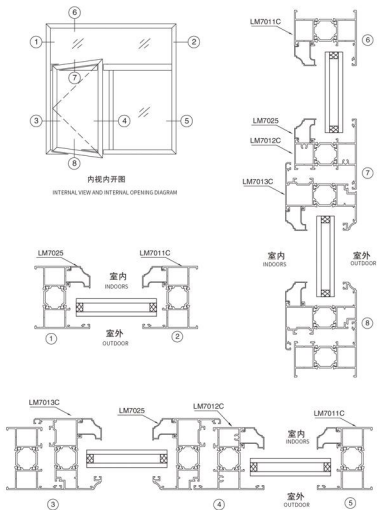
**LM70系列隔热外开窗**  
 LM70 SERIES INSULATED INWARD-OPENING WINDOWS

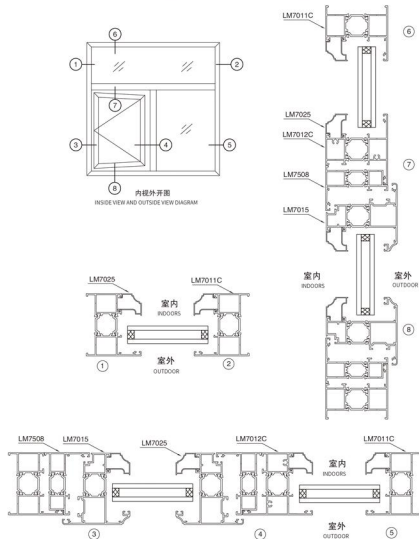

图中所示为理论重量, 客户可根据需要的厚度订购, 实际重量以过磅时重量为准。





图中所示为理论重量, 客户可根据需要的厚度订购, 实际重量以过磅时重量为准。

编号 Number	LM7011C
名称 Name	LM7011C
框 box	
壁厚 Wall thickness	1.35mm
米重 Mi Zhong	1.16kg/m

编号 Number	LM7509
名称 Name	LM7509A
外开扇 External sash panel	
壁厚 Wall thickness	1.4mm
米重 Mi Zhong	1.609kg/m

编号 Number	LM7012C
名称 Name	LM7012C
框 profile	
壁厚 Wall thickness	1.35mm
米重 Mi Zhong	1.359kg/m

编号 Number	LM7507
名称 Name	LM7507A
外开扇 External sash panel	
壁厚 Wall thickness	1.4mm
米重 Mi Zhong	1.244kg/m

编号 Number	LM7013C
名称 Name	LM7013D
内开扇 Inner opening fan	
壁厚 Wall thickness	1.35mm
米重 Mi Zhong	1.411kg/m

编号 Number	LM7508
名称 Name	LM7508B
转换框 Conversion box	
壁厚 Wall thickness	1.4mm
米重 Mi Zhong	0.982kg/m

编号 Number	LM7014
名称 Name	LM7014B
外开扇 Inner opening panel	
壁厚 Wall thickness	1.35mm
米重 Mi Zhong	1.557kg/m

编号 Number	LM7013YX
名称 Name	LM7013YX
压线 Pressing the line	
壁厚 Wall thickness	0.8mm
米重 Mi Zhong	0.211kg/m

编号 Number	LM7015
名称 Name	LM7015A
外开扇 Casement opening fan	
壁厚 Wall thickness	1.35mm
米重 Mi Zhong	1.411kg/m

编号 Number	LM7025
名称 Name	LM7025
压线 Pressing the line	
壁厚 Wall thickness	0.8mm
米重 Mi Zhong	0.188kg/m

编号 Number	LM7026A
名称 Name	LM7026A
压线 Pressing the line	
壁厚 Wall thickness	0.8mm
米重 Mi Zhong	0.178kg/m

编号 Number	ZJ-80A
名称 Name	ZJ-80A
转角 Turn the corner	
壁厚 Wall thickness	1.2mm
米重 Mi Zhong	0.805kg/m

编号 Number	LM8008
名称 Name	LM8008
压线 Pressing the line	
壁厚 Wall thickness	0.9mm
米重 Mi Zhong	0.293kg/m

编号 Number	Z3
名称 Name	Z3
压线 Pressing the line	
壁厚 Wall thickness	1.2mm
米重 Mi Zhong	1.2kg/m

编号 Number	ZJ-70
名称 Name	ZJ-70
90度转角 90-degree turn	
壁厚 Wall thickness	1.2mm
米重 Mi Zhong	0.943kg/m

编号 Number	Z33
名称 Name	Z33
压线 Pressing the line	
壁厚 Wall thickness	1.7mm
米重 Mi Zhong	1.7kg/m

编号 Number	ZJ-70A
名称 Name	ZJ-70A
转角 Turn the corner	
壁厚 Wall thickness	1.2mm
米重 Mi Zhong	0.711kg/m

编号 Number	ZJ-80
名称 Name	ZJ-80
90度转角 90-degree turn	
壁厚 Wall thickness	1.2mm
米重 Mi Zhong	1.066kg/m

图中所示为理论重量, 客户可根据需要的厚度订购, 实际重量以过磅时重量为准。

图中所示为理论重量, 客户可根据需要的厚度订购, 实际重量以过磅时重量为准。







**LM85系列双内开窗**

LM85 SERIES DOUBLE INWARD-OPENING WINDOWS

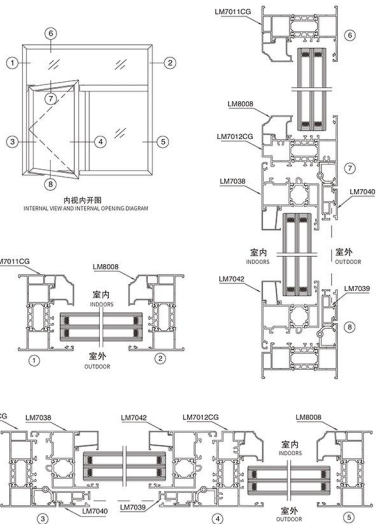

编号 Number	LM7011CG
名称 Name	平齐框 Flush frame
壁厚 Wall thickness	1.35mm
米重 M.Zhong	1.298kg/m



编号 Number	FM8008
名称 Name	平齐压线 Flush the line
壁厚 Wall thickness	0.9mm
米重 M.Zhong	0.293kg/m



编号 Number	LM7012CG
名称 Name	平齐框 Ping Qi Ting
壁厚 Wall thickness	1.35mm
米重 M.Zhong	1.437kg/m

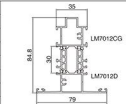

编号 Number	33
名称 Name	压线 Pressing the line
壁厚 Wall thickness	1.7



编号 Number	LM7038
名称 Name	内开扇 Inner opening fan
壁厚 Wall thickness	1.35mm
米重 M.Zhong	1.44kg/m

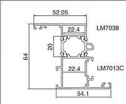

编号 Number	LM7011YX
名称 Name	压线 Pressing the line
壁厚 Wall thickness	0.9mm
米重 M.Zhong	0.307kg/m



编号 Number	LM7039
名称 Name	纱扇 Gause fan
壁厚 Wall thickness	1.2mm
米重 M.Zhong	0.4kg/m

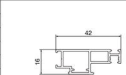

编号 Number	LM7041
名称 Name	压线 Pressing the line
壁厚 Wall thickness	1.3mm
米重 M.Zhong	0.16kg/m



编号 Number	LM7040
名称 Name	纱扇框 Gear fan frame
壁厚 Wall thickness	1.3mm
米重 M.Zhong	0.17kg/m

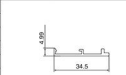

编号 Number	LM7042
名称 Name	压线 Pressing the line
壁厚 Wall thickness	1.3mm
米重 M.Zhong	0.18kg/m



图中所示为理论重量, 客户可根据需要的厚度订购, 实际重量以过磅时重量为准。

The theoretical weight is shown in the picture. Customers can order according to the thickness they need. The actual weight is subject to the weight at the time of weighing.

图中所示为理论重量, 客户可根据需要的厚度订购, 实际重量以过磅时重量为准。

The theoretical weight is shown in the picture. Customers can order according to the thickness they need. The actual weight is subject to the weight at the time of weighing.



编号 Number	001H-MQ
名称 Name	
壁厚 Wall thickness	2.0mm
米重 Mi Zhong	1.6kg/m



编号 Number	006G-MQ
名称 Name	
壁厚 Wall thickness	2.0mm
米重 Mi Zhong	0.33kg/m



编号 Number	002G-MQ
名称 Name	
壁厚 Wall thickness	1.6mm
米重 Mi Zhong	0.3kg/m



编号 Number	007D-MQ
名称 Name	
壁厚 Wall thickness	2.0mm
米重 Mi Zhong	0.58kg/m



编号 Number	003K-MQ
名称 Name	
壁厚 Wall thickness	1.9mm
米重 Mi Zhong	0.866kg/m

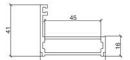

编号 Number	008G-MQ
名称 Name	
壁厚 Wall thickness	2.0mm
米重 Mi Zhong	0.36kg/m



编号 Number	004S-MQ
名称 Name	
壁厚 Wall thickness	2.0mm
米重 Mi Zhong	1.02kg/m



编号 Number	009D-MQ
名称 Name	
壁厚 Wall thickness	2.0mm
米重 Mi Zhong	0.63kg/m



编号 Number	005J-MQ
名称 Name	
壁厚 Wall thickness	2.2mm
米重 Mi Zhong	2.4kg/m



编号 Number	010H-MQ
名称 Name	
壁厚 Wall thickness	2.2mm
米重 Mi Zhong	2.12kg/m



编号 Number	011G-MQ
名称 Name	
壁厚 Wall thickness	1.6mm
米重 Mi Zhong	0.3kg/m



编号 Number	130 x 65MK
名称 Name	
壁厚 Wall thickness	3.0mm
米重 Mi Zhong	3.7kg/m



编号 Number	20FK-MQ
名称 Name	
壁厚 Wall thickness	2.0mm
米重 Mi Zhong	0.27kg/m



编号 Number	137 x 67MK
名称 Name	
壁厚 Wall thickness	3.3mm
米重 Mi Zhong	4.12kg/m



编号 Number	100 x 60MK
名称 Name	
壁厚 Wall thickness	2.9mm
米重 Mi Zhong	2.95kg/m

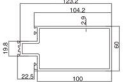

编号 Number	150 x 60DC
名称 Name	
壁厚 Wall thickness	2.5mm
米重 Mi Zhong	3.27kg/m



编号 Number	120 x 60
名称 Name	
壁厚 Wall thickness	2.7kg/m
米重 Mi Zhong	2.7kg/m

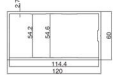

编号 Number	157 x 60YK
名称 Name	
壁厚 Wall thickness	2.9mm
米重 Mi Zhong	3.26kg/m



编号 Number	120 x 60MK
名称 Name	
壁厚 Wall thickness	2.9mm
米重 Mi Zhong	3.18kg/m



编号 Number	157 x 66MK
名称 Name	
壁厚 Wall thickness	3.3mm
米重 Mi Zhong	4.48kg/m

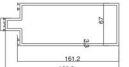

图中所示为理论重量, 客户可根据需要的厚度订购, 实际重量以过磅时重量为准。

图中所示为理论重量, 客户可根据需要的厚度订购, 实际重量以过磅时重量为准。